



PVD Coatings for Stamping and Forming



- **Cost reduction**

Less quantity of tooling to be used for manufacturing multiple lots due to reduced wear.

- **Abrasive wear resistant**

The high hardness of the coating is up to 3 times higher than the hardness of tempered steel.

- **Reduction in the consumption of stamping lubricants**

Due to the low coefficient of friction of the coating, it performs the function of a solid lubricant.

- **Eliminates machine stoppage for eventual polishing and cleaning**

The coating process prevents the adhesion of material and risks resulting from the stamping process.

- **Best quality of stamped product**

The protection generated in the geometry of the tools by the coating ensures high stamping quality, especially in the case of non-ferrous materials.

- **Reduction of thermal fatigue in warm and hot work dies**

In cases where DUPLEX processes are used.

- **Replacement in the manufacture of carbide tools**

For example, in some cases it is possible to substitute carbide for coated tool steel.

- **Replacing environmentally harmful disposal technologies**

As is the case with hard chromium and chemical nickel.

PVD Coatings for Stamping and Forming

Our PVD coatings were specially developed to reduce friction, increase surface hardness, corrosion resistance of molds and dies in different applications and working conditions. Beside increased tool life the coatings allow longer maintenance cycles and faster tool changes. With over 30 years of experience in the segment, our R&D center has been developing high-performance coatings dedicated to molds and dies.



■ BENEFITS OF PVD COATING IN THE STAMPING PROCESS

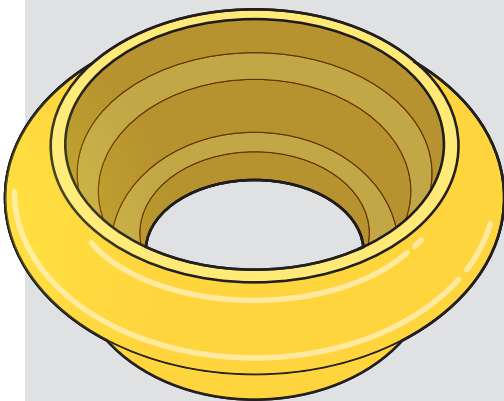

Aluminum Forming

- Eliminates aluminum adhesion to tool surface during the manufacturing process.
- Increased productivity.
- Longer tool life.
- Cost reduction by manufacturing smaller quantities of tools.
- Eliminates the use of oil in the forming process.
- Less machine downtime for maintenance and tool change.

Punches and Drawing Dies

- Easy production of complex parts.
- Reduction in oil consumption in the process.
- Less distortion in the geometric lines of the produced parts.
- Greater dimensional reliability.
- Higher productivity on automated machines.

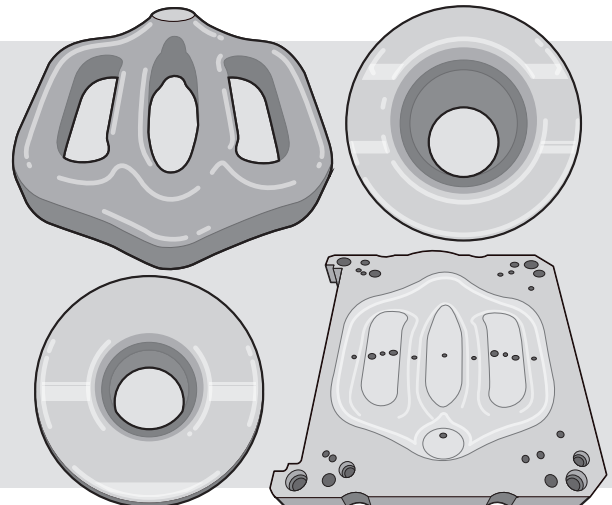

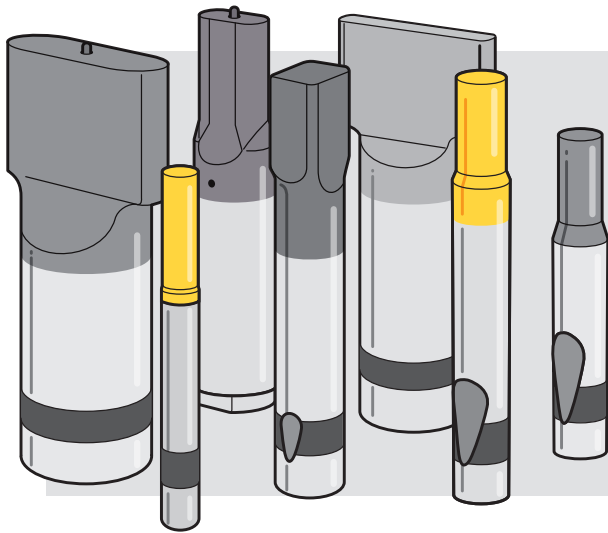

Piercing and Fine Blanking Tools

- Less machine effort when performing tasks.
- Longer punch life.
- Longer machine life due to the low torque to perform the tasks.
- Greater dimensional reliability in the process.
- Eliminates material adhesion to the punch surface.

Sheet Forming Dies

- Eliminates risk of breakage.
- Less oil consumption during production.
- Prevents plate breakage during production.
- Improved quality of the stamped item.
- Longer machine life due to the low torque to perform the tasks.

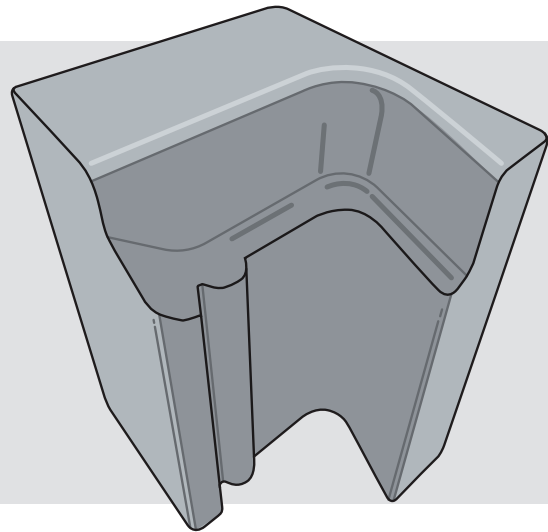

Hidden cost of stamping process (iceberg)

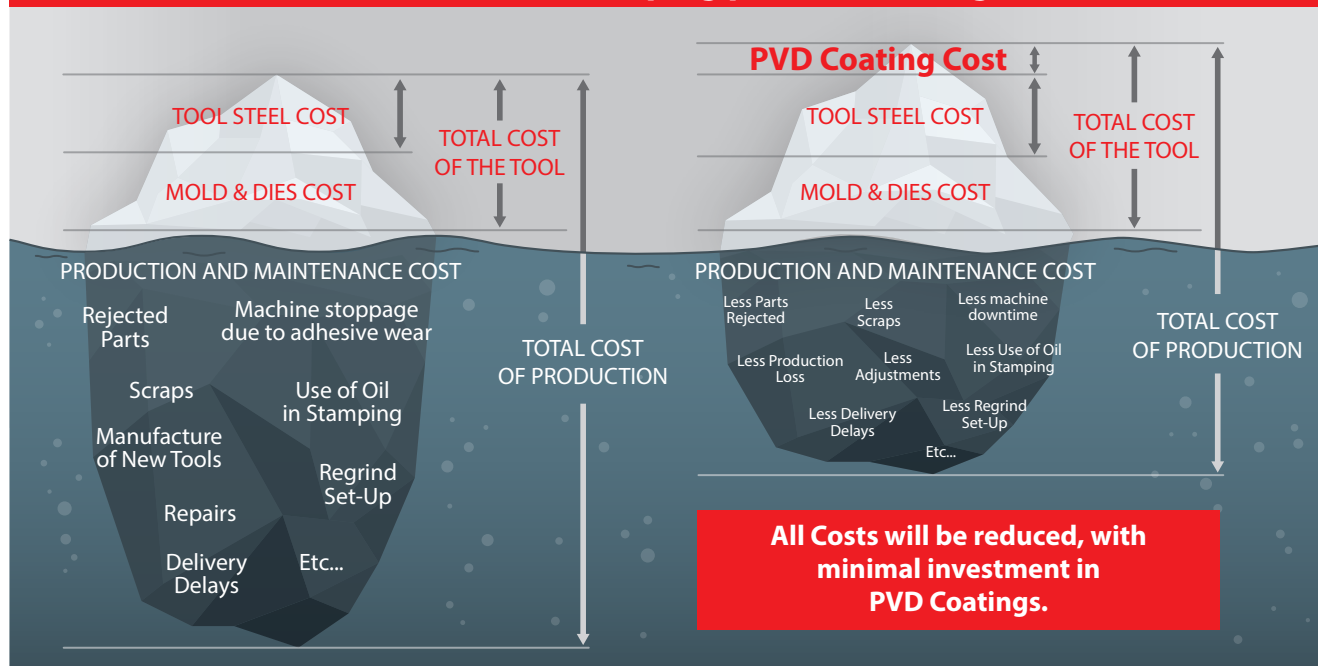

SPECIFICATIONS OF COATINGS FOR STAMPING AND FORMING MOLDS AND DIES

Coating Features	TiN	HP Fama*	HP Form*	HP Dura*	HP Cera*
	Composition	TiN	TiC Based	TiAlN Based	AlCr Based
Hardness (GPa)	30 GPa	35 GPa	37 GPa	38 GPa	30 GPa
Coefficient of friction* <small>(dry against steel)</small>	0.25	0.25	0.4	0.33	0.1
Coating thickness (µm)	2 ~ 4 µm	4 ~ 6 µm	4 ~ 6 µm	4 ~ 6 µm	2.5 ~ 3.5 µm
Maximum oxidation temperature (°C)	500°C	400°C	850°C	1,100°C	550°C
Coating deposition temperature (°C)	450°C	450°C	450°C	450°C	450°C
Coating Color	Gold	Grey	Violet	Dark Grey	Dark Grey
Coating structure	Monolayer	Multilayer	Multilayer	Multilayer	Multilayer

If pre-polishing is required, please contact our sales department for more information.

* Duplex coating available (Nitride + Coating), for more information, please contact our sales department.

The depth of nitride will depend on the material of the mold.

INDICATED APPLICATIONS

Group	Material		Recommended Coatings														
	Subgroup	Plate thickness	Forming				Cut				Fine Cut				Drawing		
			Die		Punch		Die		Punch		Die		Punch		Die	Punch	
○	⊙	○	⊙	○	⊙	○	⊙	○	⊙	○	⊙	○	⊙	○	⊙		
S steels	Carbon steel	SAE 1010 • 1020	0 ~ 3mm	HP Fama	HP Form	HP Fama	HP Dura	HP Fama	HP Dura	HP Form	HP Dura	HP Fama	HP Form	HP Fama	HP Form	-	-
			> 3 mm	HP Fama Duplex	HP Dura Duplex	HP Fama Duplex	HP Form Duplex	HP Fama	HP Dura	HP Form	HP Dura	HP Dura	-	HP Dura	-	-	-
	SAE 1035 • 1045 • 1050 • 1050 • 1070 • 1090	0 ~ 3 mm	HP Fama Duplex	-	HP Fama Duplex	HP Dura Duplex	HP Fama	HP Dura	HP Form	HP Dura	HP Dura	-	HP Dura	-	-	-	
		> 3 mm	HP Fama Duplex	-	HP Fama Duplex	HP Dura Duplex	HP Fama	HP Dura	HP Form	HP Dura	HP Dura	-	HP Dura	-	HP Fama Duplex	HP Dura Duplex	
	Advanced High Strength Steels	DP, CP, FP • TRIP	0 ~ 3 mm	HP Fama Duplex	HP Dura Duplex	HP Fama Duplex	HP Dura Duplex	HP Fama	HP Dura	HP Form	HP Dura	HP Fama	-	HP Dura	-	HP Fama Duplex	HP Dura Duplex
> 3 mm	HP Fama Duplex		HP Dura Duplex	HP Fama Duplex	HP Dura Duplex	HP Fama Duplex	HP Dura Duplex	HP Form Duplex	HP Fama Duplex	HP Fama	-	HP Dura	-	HP Fama Duplex	HP Dura Duplex		
Stainless Steel	200 • 300 • 400	All thicknesses	HP Fama Duplex	-	HP Fama Duplex	-	HP Fama	HP Dura	HP Fama	HP Dura	N/A	-	N/A	-	HP Fama Duplex	HP Dura Duplex	
Aluminum	All	Aluminum-Manganese / Aluminum Magnesium / Aluminum-Magnesium-Silicon / Aluminum-Zinc	All thicknesses	HP Cera	HP Fama	TiN	HP Cera	TiN	HP Dura	TiN	HP Dura	N/A	-	N/A	-	HP Fama Duplex	HP Dura Duplex
Copper	All	Aluminum Copper, Silicon Copper and Beryllium Copper	All thicknesses	HP Fama	HP Cera	HP Cera	HP Fama	HP Dura	-	HP Dura	-	N/A	-	N/A	-	HP Fama	HP Cera

⊙ Excellent ○ Good

PrimCoat

PrimCoat PVD Technology India Private Limited

Pune Plant

Plot No. G-22, MIDC Phase II
Chakan Industrial Area - Savardari Village
Tal Khed, Pune - 410 501
Maharashtra, India

raman@primcoat.com | www.primcoat.com | Tel.: +91 755 022 3546

Bangalore Plant

Plot No: 22-J2, Attibele Industrial Area
Survey No 125, 126, 127 - Ichhangur Village
Attibele Hobli, Anekal Taluk, Bangalore- 562 107
Karnataka, India

Chennai Plant

Plot No: K-16, Phase II
SIPCOT Industrial Park - Mambakkam Village
Sriperumbudur Taluk, Kancheepuram - 602105
Tamil Nadu, India

www.primuscoating.com

PC-1123-SF

PRIMCOAT